

# DESIGN, FABRICATION AND IMPLEMENTATION OF DEWEEDING ROBOT

<sup>1</sup>MATHESH K S, <sup>2</sup>SATHEESH KUMAR G

<sup>1,2</sup>Department of Mechanical Engineering, SSN College of Engineering, Kalavakkam, India  
E-mail: <sup>1</sup>mathesh.k.s@gmail.com, <sup>2</sup>satheeshkumarg@ssn.edu.in

---

**Abstract** - Robotics is the human interfaced machine which must be used for to fulfill the desired work where human practices are low. Generally design of a robot involves in various types of analyses that invariably include structural, numerical, kinematic, and dynamic experiments. A robot designed as a solution for weeding problems would have to consider all the stages of plant growth. Initially a detailed description of the framework of the proposed robot is provided for simplicity along with the known design parameters. The primary design parameter of 'the robot and its cutting mechanism' establishes certain geometric and structural constraints on the design of worm gear, worm and blades which is attached with motors for comprising the cutting mechanism of the robot. This relationship is studied in order to improve the speed of cutting the weeds by image processing of camera for the differentiation of the weeds and plants by the robot. A significant reduction in size is achieved by working on these variables which leads to the improvement in the functional aspects and reduces the innovation of bigger machine used for these weeding purposes in modern world. There are 3 motors in which 2 motors are used for movement and 1 motor is used for actuating the cutting mechanism. This whole mechanism is controlled by Arduino UNO controller and MatLAB software. Arduino UNO controls the movement of the robot and the MatLAB software controls the differentiation of the plants and the weeds depending on the task allocated to the robot.

**Keywords** - deweeding robot; structural analysis of cutting mechanism; control architecture; machine vision; image processing based output.

---

## I. INTRODUCTION

Robots are a solution for the problems faced by the humans where they are involved with Dull, Dirty, Difficult and Dangerous jobs. Since agriculture has been labour intensive in India, non-availability of labourers has caused huge problems for the farmers leading to lesser productivity. The few technologies that have been developed for weeding problems are either inefficient or again dependent on humans for their usage. The robot which is used now in other countries are very huge than the plant crops and are suitable for large farmlands. The herbicides sprayed on the weeds get directly influenced on the plant crops which cause the environmental hazard on plant crops and reduces the soil fertility. This develops a situation that plant crops gets affected and their yield gets decreased. The bigger machine does not spray the herbicides applied to the right place at the right time and exactly with the right amount too. Nowadays youths are away from the agricultural activities and there is also scarcity of labour in agriculture. Applying robots for deweeding will helped to create several advancements to the agro based industry and helping farmers to save money and time.

A thorough study of image processing and finding the differentiation between plant leaf and weed leaf is done by Image Acquisition, Image Pre-processing, Image Segmentation, Feature Extraction, Statistical Analysis [1]. Smita Naikwadi *et al.*, The digital image analysis is used for the identification of the weeds crops across the plant crops [2]. J. Hemming *et al.*, The method of identification of weed plants

based on the colour, edge detection and histogram matching[3]. Kamaljot Singh Kailey *et al.*, The algorithm is developed for the detection of broad leaves grass plant by decreasing the resolution of original image, convert the colour image to gray scale, performing Fourier transform to find the border of the image [4]. Gerrit Polder *et al.*, The robot is introduced to run in predefined platform to find the weeds that are predefined inside the program without image processing using sensor to find the weeds [5]. Ajit G Deshmukh *et al.*, The vision based guidance method is introduced to find the weeds from the plant crops in the farmland and the vehicle motion is controlled with and unbalancing motion of the robot [6]. G.Bhanumathi *et al.*, The robotic platform is introduced while travelling between rice seedlings stably against irregular land surface of a paddy field [7]. Gook-Hwan Kim *et al.*, To control the weeding robot automatic navigation, motion control and motors driver board and real time video capture board respectively were designed. The visual navigation algorithm implemented on the video capture module [8]. Chuanbo Qin *et al.*, The weed detection system and the weed classification algorithm which is applied for autonomous weed controller robot. To achieve this objective by using the variety of machine vision algorithm the weeds and crops were classified. This entire process is implemented by LabVIEW software and it is suitable for real time field purpose [9]. B. S. Sathishkumar *et al.*, A small, portable and reliable platform will automatically survey the farmland, detect diseases as well as spray the pesticide. The robot include a camera that captures pictures by which weeds and plants are differentiated [10]. Sai Kirthi Pilli *et al.*,

In this paper the designing of a robot with camera for the identification of the weeds and plant crops by image processing is discussed. It is then followed by a discussion on structural analysis of the cutting mechanism used in the robot for cutting the weeds. Finally the proposed control movement of the robot achieved by Arduino UNO and differentiation of weeds from the plant crops by Image Processing with help of MatLAB.

## II. ANATOMY OF ROBOT

### A. Description of the robot

The proposed robot is designed to operate for the inspection of grass weeds present on the farmland with plant crops. The robot is capable of moving in all direction has the dimension of length 300mm, breath 200 mm, height 150mm.

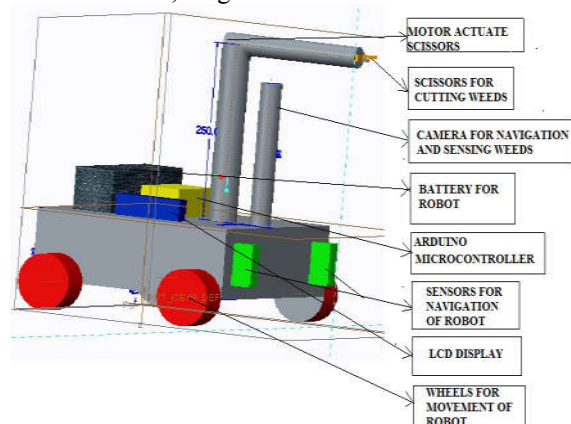

Fig. 1. CAD model of proposed robot

The purpose of the robot is the simple and portable size with low cost. So the design of the robot is designed in such a way that it must move between the plant crops which are being placed in a distance of 1-2 feet which enables the robot to navigate in between the plant crops to find the grass weeds. For this purpose the size constrains is done to develop the robot to work efficiently according to the given parameters. Fig. 1 shows the model of the proposed deweeding robot.

### B. Cutting mechanism of the proposed robot

The cutting mechanism is being used for cutting the weeds when the camera senses it. The cutting mechanism is actuated with help of the motor which is present in the top of the robot. The cutting mechanism actuates the cutting action which is controlled by the Arduino UNO microcontroller. The cutting mechanism is made up of 2 worm gears, worm, 2 blades connected with a dc gear motor. The dimension of cutting mechanism is given below:

Worm Gear:

Diameter of Dedendum circle (Outer circle) = 33mm

Tooth Height = 3mm

Tooth Thickness = 4mm

Centre hole = 6mm

Number of Teeth in Gear = 25

Worm:

Length of worm = 32mm

Thread Length = 22mm

Worm Diameter = 17.5mm

Blade Dimensions:

Length of Blade = 250mm

Width of Blade = 20mm

Thickness of Blade = 2mm

Calculation of Cutting Mechanism

Motor Specification:

Rated Voltage = 12 V

Rated current = 8 amp

Rated speed = 65 rpm

No load speed = 90 rpm

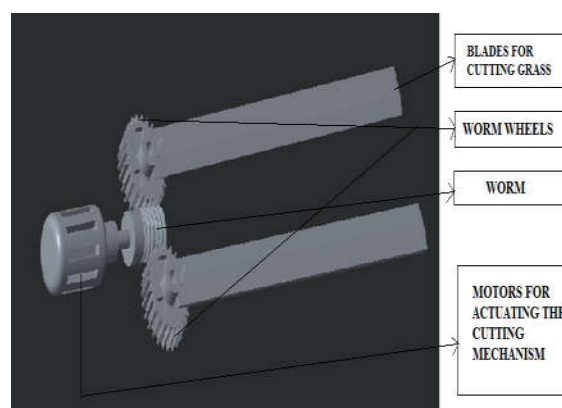

Fig. 2. Cutting mechanism of the deweeding robot

The major parameters listed above are dependent on atleast two or more sub parameters. For ex., the length of the cutting blades is dependent on the sub parameters like camera that can locate the weed which is from a distance of 20 centimeters from the robot. Fig. 2 shows cutting mechanism used for cutting the weeds on the farmland. The other sub-parameters are listed below:

- blade length
- camera resolution
- blade thickness
- wheel diameter
- base plate thickness
- ground clearance from the base

## III. STRUCTURAL ANALYSIS OF ROBOT

For definite load, the reaction of cutting mechanism body is determined by using the structural analysis procedure. Finding the internal stress, displacement and deformation is the response of cutting mechanism. The whole cutting mechanism body is made up of worm gear made up of plastics, worm made up of plastics and blades are made up of stainless steel. The density of that stainless steel is  $7850 \text{ kg m}^{-3}$  and its Young's modulus 200 Gpa.

Generally the cutting mechanism is actuated by the dc geared motor connected with the worm present in the

centre of the worm gear. The fixed support beam is given to the motor. This is due to the only shaft rotation causes the expanding and contracting of the blades in horizontal direction. When worm gears rotates, the blades gets expanded and contracted and cuts the weed. So the twisting moment of the motor shaft is given as 14.11 N-m. Then the equivalent stress is found with help of twisting moment.

**C. Structural analysis of the cutting mechanism during meshed**

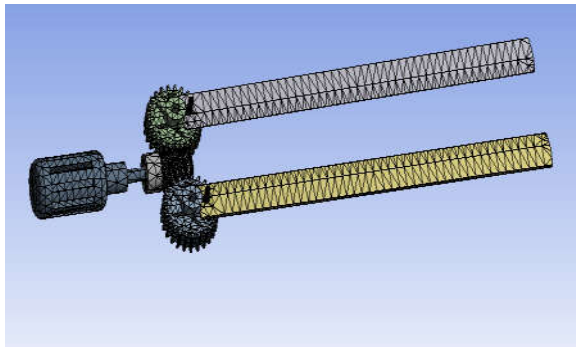

Fig. 3 Meshed part of the cutting mechanism

**D. Fixed support given to the motor**

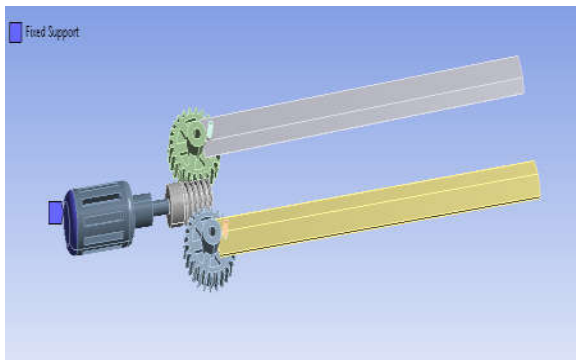

Fig. 4 Fixed supports given to the motor

**E. Twisting moment given to the shaft for the rotation of the worm and resulting expanding and contracting movement of the blades.**

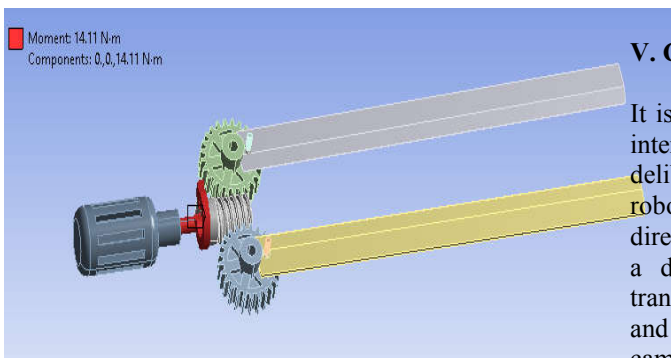

Fig. 5 Moment given to shaft of the motor to rotate worm

**F. Equivalent stress on the cutting mechanism in normal position**

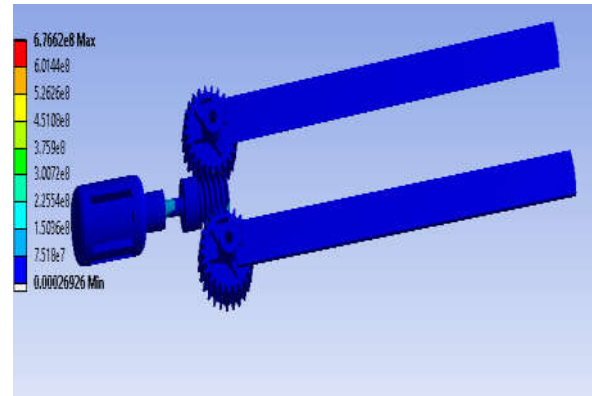

Fig. 6 Equivalent stress on the cutting mechanism

**G. Total deformation applied on the cutting mechanism in normal position**

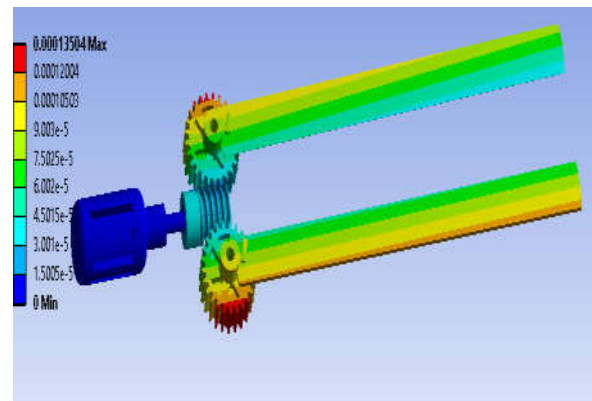

Fig. 7 Total deformation of the cutting mechanism

**IV. RESULT AND DISCUSSION**

The minimum equivalent stress given to the whole cutting mechanism is 2.692 Pa and maximum equivalent stress given to the whole cutting mechanism is 6.767 Pa. The total deformation of the two stainless steel blades is 1.35 m. The force experienced in the two blades during cutting is 20.28 N.

**V. CONTROL ARCHITECTURE**

It is usually used to represent the ways in which the internally employed camera and three motors are deliberated to change robots' behaviour. During the robot movement and forward, backward, left, right directions are being moved using Zigbee controller in a distance of 5-10 m. Through the radio wave transmission the robot is autonomously controlled and the grass weed verification is done through the camera present on the robot.

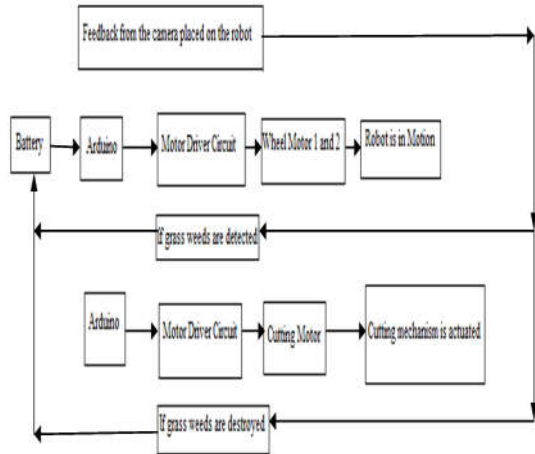

**A. Workplan of the movement of the robot**

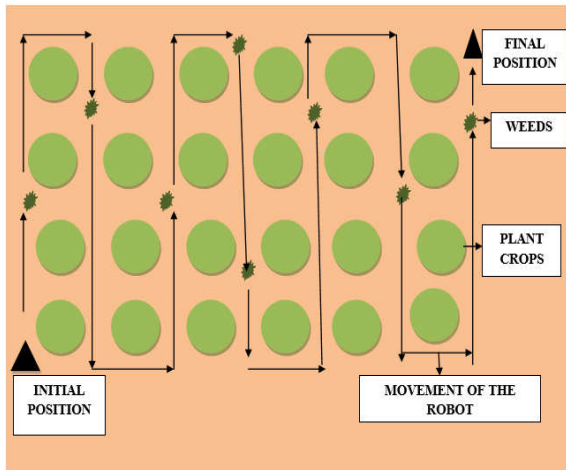

**Fig. 8 Workplan of movement of robot**

The robot moves in the manner of Raster scan method for the identification of the grass weeds in the farmland. Fig. 8 represents the workplan of the robot. By this movement the identification of the grass weeds is made accurately and removal of the grass weeds is done precisely. Setting initial position and final position on the farmland helps the user to find the exact location of the robot in the farmland.

**B. Algorithm for the movement of the robot in the farmland**

- Step 1: Start
- Step 2: Initialize the input parameters camera and sensor
- Step 3: Image of the weeds is loaded in controller and the motor driver circuit is actuated.
- Step 4: Wheel motors are actuated and robot is moving in straight direction
- Step 5: Camera senses the grass weeds and signal is sent to controller

Step 6: Microcontroller verifies with the grass weeds image and actuates the motor driver circuit and robot stops.

Step 7: Microcontroller actuates the cutting motor and cutting mechanism cuts the grass weeds with the help of the camera.

Step 8: Camera checks whether the grass weed is destroyed or not.

Step 9: If the grass weeds is not destroyed means go to step 7

Step 10: If the grass weeds is destroyed microcontroller actuates the wheel motor and robot is moving and camera is searching for the grass weeds.

Step 11: Surveying the farmland is clear without grass weeds then goes to the final position.

Step 12: Stop

**C. Flowchart representing the working of robot**

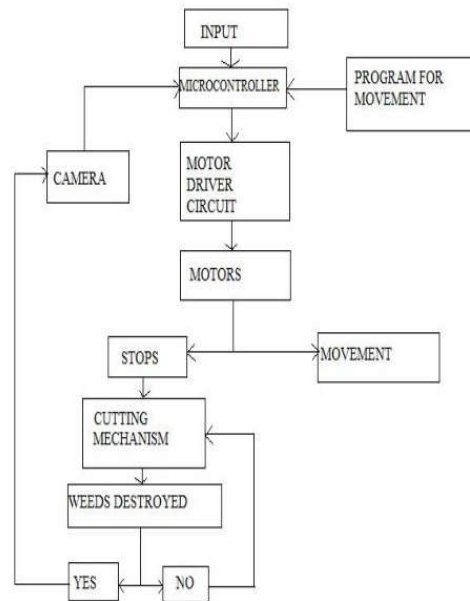

**Fig. 9 Flowchart of working of robot**

Based on the algorithm for the movement of the robot in the farmland the flowchart of working of robot is drawn. Initially the input is given to the microcontroller. The loaded program for the movement makes the motor driver circuit to move the robot in the forward direction. When camera senses the grass weeds the motors gets stopped and the cutting mechanism gets actuated. By this the grass weed is cut downed. Again the camera checks whether the grass weed is destroyed or not. If weed is destroyed means the driving motor gets actuated and

the robot is in motion. If not means again the cutting mechanism is actuated and cuts the weeds. This whole process is represented in the Fig .9 in the flowchart of working of the robot.

## CONCLUSION AND RESULTS

In this paper the grass weeds are being deweeded by using predetermined algorithm. During the motion of the robot the grass weeds get sensed and the robot has been stopped for the cutting of the grass weeds. The overall scanning time of the grass weeds is about 6-10 seconds. This is based on the colour and dimension of the grass weed present in the farmland. The orientation of the robot body that is camera to the grass weeds is the tough task. The avoidance of the plant crops during the motion of the robot is achieved. The battery optimization is done with the help of two 9 volt batteries and one 12 volt battery. This is compared to be cost effective than the bigger batteries used nowadays. The size reduction of the robot made the robot to move properly without any tilt or imbalance on the motion of the robot.

## REFERENCES

- [1] Smita Naikwadi, Niket Amoda (2013), "Advances In Image Processing For Detection Of Plant Diseases", International Journal of Application or Innovation in Engineering & Management, Volume 2, Issue 11, November, (168-175).
- [2] J. Hemming, T. Rath(2013), "Computer Vision based Weed Identification under Field Conditions using Controlled Lighting", Journal Classification System: PA (Precision Agriculture) , (1-17).
- [3] Kamaljit Singh Kailey, Gurjinder Singh Sahdra (2012), "Content-Based Image Retrieval (CBIR) For Identifying Image Based Plant Disease", ISSN: 2229-6093, Volume 3, (1099-1104).
- [4] Gerrit Polder, Frits K. van Evert, Arjan Lamaker, Arjan de Jong, Gerie van der Heijden, Lambertus A.P. Lotz, Ton van der Zalm, Corné Kempenaar(2013), "Weed Detection Using Textural Image Analysis", (1-6).
- [5] Ajit G Deshmukh & V.A. Kulkarni (2013), "Advanced Robotic Weeding System", ISSN (PRINT): Volume -1, Issue -3,(51-56).
- [6] G.Bhanumathi, B.Subhaker (2015), "Smart Herbicide Sprayer Robot for agriculture fields", International Journal of Computer Science and Mobile Computing, Vol.4 Issue.7, (571-574).
- [7] Gook-Hwan Kim, Sang-Cheol Kim, Young-Ki Hong, Kil-Su Han, Soon-Geul Lee (2012), "A Robot Platform for Unmanned Weeding in a Paddy Field Using Sensor Fusion", 8th IEEE International Conference on Automation Science and Engineering, August 20-24, (904-907).
- [8] Chuanbo Qin, Qiliang Du, Lianfang Tian and Xiaogang Huang, (2012), "The Control System Design of Automatic Weeding Robot Based on Visual Navigation", IEEE International Conference on Robotics and Biomimetics, December 11-14, (956-961).
- [9] B. S. Sathishkumar, (2015), "Developing a Real Time Smart Herbicide Sprayer Robot and Automatic Weed Detection System", International Journal of Emerging Technology and Advanced Engineering, ISO 9001:2008 Certified Journal, 5(1), Volume 5, Issue 1, January, (323-326).
- [10] Sai Kirthi Pilli1, Bharathiraja Nallathambi, Smith Jessy George, Vivek Diwanji (2015), "eAGROBOT- A Robot for Early Crop Disease Detection using Image Processing", IEEE Sponsored 2nd International Conference On Electronics And Communication System, (1684-1689).

★ ★ ★